

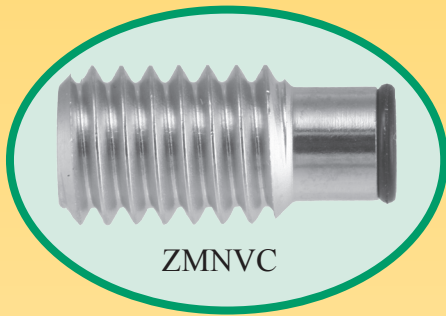

METRIC PRECISION ORIFICES AND MINIATURE CHECK VALVES

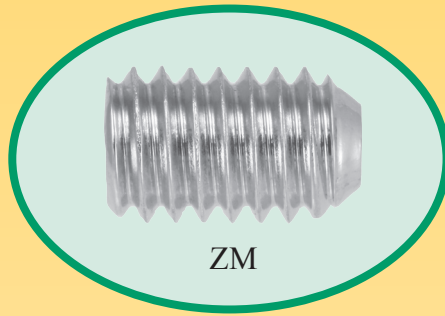

ZMNVC



ZM

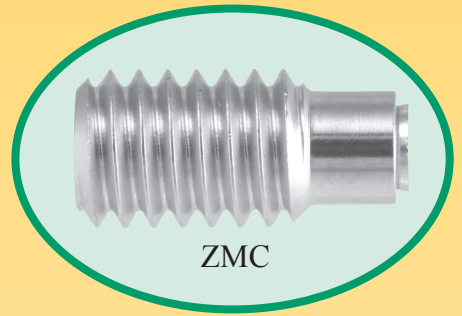

ZMC

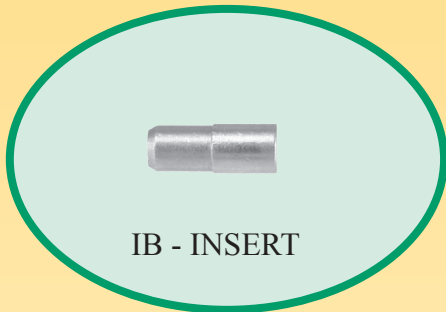

IB - INSERT

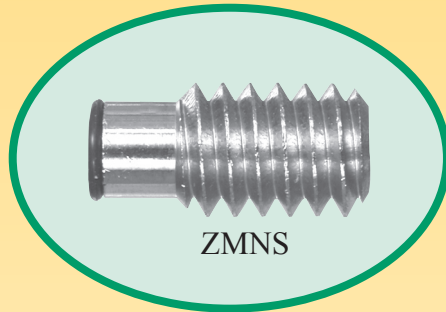

ZMNS

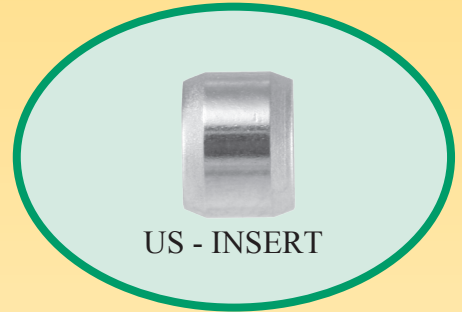

US - INSERT

O'Keefe Controls Co.

Metal Orifice Assemblies

METRIC THREADED INSERTS

Description

Set screw style threaded orifice inserts can be installed in fittings, manifolds or custom parts to establish flow rates of liquids or gases. Standard size orifices range from .10 mm to 1.60 mm.

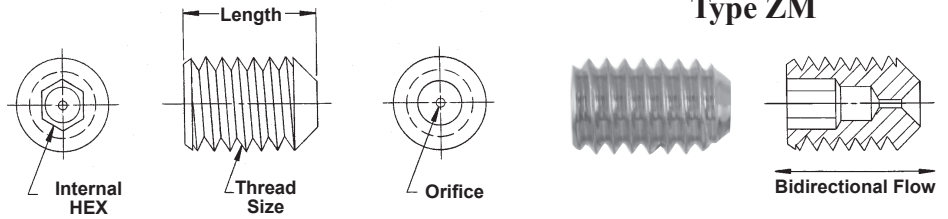

PART NUMBER SYSTEM

<u>TYPE</u> ZM		<u>ORIFICE</u> <u>SIZE NO.</u>	<u>THREAD</u> <u>SIZE</u>	<u>LENGTH NO.</u>	<u>MATERIAL</u>	
<u>Standard Sizes</u>	<u>Orifice</u> <u>Dia.*</u> <u>mm.</u>	<u>Standard Size</u> <u>Range</u>	<u>Thread Size</u>	<u>Length</u> <u>mm</u> <u>No.</u>		
4	.10	4-35	<u>Thread Size</u> M3 x .5 mm	4 mm 4	SS 18-8 SS	
5	.13		<u>Hex Size</u> 1.5 mm			
6	.15		4-35	<u>Thread Size</u> M4 x .7 mm		5 mm 5
7	.18			<u>Hex Size</u> 2.0 mm		
8	.20			4-63		<u>Thread Size</u> M5 x .8 mm
9	.23	<u>Hex Size</u> 2.5 mm				
10	.26	4-63				<u>Thread Size</u> M6 x 1.0 mm
11	.28		<u>Hex Size</u> 3.0 mm			
12	.31		4-63			<u>Thread Size</u> M8 x 1.25 mm
13	.33			<u>Hex Size</u> 4.0 mm		
14	.36			4-63		<u>Thread Size</u> M10 x 1.50 mm
15	.38	<u>Hex Size</u> 5.0 mm				
16	.41					
17	.43					
18	.46					
19	.48					
20	.51					
21	.53					
22	.56					
23	.58					
24	.61					
25	.63					
26	.66					
27	.69					
28	.71					
29	.74					
31	.79					
32	.81					
33	.84					
35	.89					
37	.94					
38	.97					
39	.99					
40	1.02					
41	1.04					
42	1.07					
43	1.09					
47	1.19					
52	1.32					
55	1.40					
60	1.52					
63	1.60					

*Consult factory for larger orifice sizes.

EXAMPLES

	<u>TYPE</u>	<u>SIZE NO.</u>	<u>THREAD SIZE</u>	<u>LENGTH NO.</u>	<u>MATERIAL</u>
1.	ZM (Type ZM)	10 (.26 mm diameter)	M3	4 (4 mm length)	SS (Stainless Steel)
2.	ZM (Type ZM)	31 (.79 mm diameter)	M6	8 (8 mm length)	SS (Stainless Steel)

Metal Orifice Assemblies

METRIC THREADED INSERTS - NOSE SEALS

Description

This type precision orifice includes an o-ring for sealing against a flat surface. The set screw style can be installed in fittings, manifolds and custom parts for accurate flow rate control of liquids or gases.

Specifications

Thread Sizes – M3.5 x 0.6, M5 x 0.8, M6 x 1, and M8 x 1.25.

Flow Direction – Suitable for flow in either direction.

Flow – See flow chart for air flow on last page.

K_v Range – .00030 to .171

Orifice Diameter Accuracy – ± .013 mm

Fluid Media – Air, Water, Gases and Liquids compatible with materials of construction.

Dimensions – See drawings this page.

Materials of Construction –
 Brass or 303 SS Body.
 Fluorocarbon or Nitrile O-ring

Maximum Operating Pressure –
 1400 kPa

Maximum Operating Temperature –
 Nitrile O-ring 70 °C.
 Fluorocarbon O-ring 166 °C.

Size Number	Orifice Dia. (mm)	Size Number Range
4	.10	Thread M3.5 x 0.6 4-31
5	.13	
6	.15	
7	.18	
8	.20	
9	.23	
10	.26	
11	.28	
12	.31	
13	.33	
14	.36	Thread M5 x 0.8 4-52
15	.38	
16	.41	
17	.43	
18	.46	
19	.48	
20	.51	
21	.53	
22	.56	
23	.58	
24	.61	Thread M6 x 1 4-81
25	.63	
26	.66	
27	.69	
28	.71	
29	.74	
31	.79	
32	.81	
33	.84	
35	.89	
37	.94	Thread M8 x 1.25 4-94
38	.97	
39	.99	
40	1.02	
41	1.04	
42	1.07	
43	1.09	
47	1.19	
52	1.32	
55	1.40	
60	1.52	
63	1.60	
67	1.70	
70	1.78	
73	1.85	
76	1.93	
79	2.01	
81	2.06	
86	2.18	
89	2.26	
94	2.39	

Construction

Type ZMNS

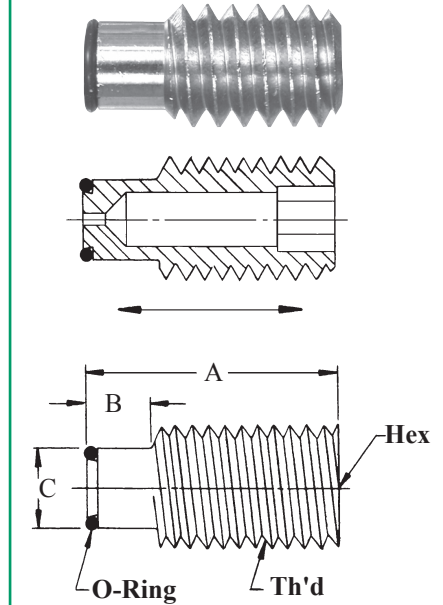

Dimensions - mm

Th'd	A	B	C	Hex
M3.5	7.87	1.97	2.29	2
M5.0	10.8	2.57	3.10	2.5
M6.0	12.7	3.81	4.45	3
M8.0	16.3	4.83	5.59	4

Part Numbers

The complete part number for an orifice assembly includes Type, Size Number, Thread Size, Body Material and O-Ring Material.

BN - Nitrile
 V - Fluorocarbon

EXAMPLES

Type	Size Number	Thread Size	Body Material	O-Ring	Part Number
ZMNS	10(.26 mm)	M3.5	BR (Brass)	BN	ZMNS-10-M3.5-BR-BN
ZMNS	20(.51 mm)	M6	SS (303 SS)	V	ZMNS-20-M6-SS-V

Installation

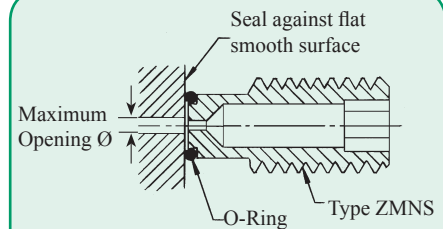

Dimensions - mm

Thread	Maximum Opening Ø
M3.5	1.20
M5.0	1.57
M6.0	2.41
M8.0	3.18

Metal Orifice Assemblies

INSERTS

Description

The inserts shown on this page are designed to press-fit into openings accurately machined in fittings, manifolds and custom parts. There is a choice of insert sizes and materials of construction.

Applications

The inserts can be used with a wide variety of fittings by accurately machining the inside of the fitting. The orifice is then pressed into the fitting for control of the flow rate of liquids or gases.

Manifolds or other custom assemblies that require flow rate control of fluids can be accurately machined to press fit the orifices shown on this page and on page 5.

General Specifications

Maximum Operating Pressure

Insert Only (see exceptions)

Brass – 13,790 kPag

303SS – 27,580 kPag

316SS – 27,580 kPag

exceptions IAS, US

Maximum Differential Pressure –
700 kPad

Flow – See flow chart for air flow on page 7.

Orifice Diameters – .10 mm to 3.18 mm. See chart at right. Consult factory for other sizes.

Orifice Diameter Accuracy – ± 0.013 mm

K_v Range – .0003 to .32 - See page 7.

Fluid Media – Air, Water, Gases and Liquids compatible with materials of construction.

Dimensions – See drawings in right hand column of this page and on page 5.

Press Fit – See drawings in right hand column of this page and on page 5.

Materials

Type IA, AM, IF – Brass or 303 SS

Type IAS – Brass, 304 SS Screen

Type IB, IE, IJ – 303 SS
IK, U

Type IL – Brass

Type IC, ID – 316 SS

Type US – 303 SS, 304 SS Screen

Size Number	Orifice Dia. mm	Size Number Range
4	.10	
5	.13	
6	.15	
7	.18	
8	.20	
9	.23	
10	.26	
11	.28	
12	.31	
13	.33	
14	.36	
15	.38	
16	.41	
17	.43	
18	.46	
19	.48	
20	.51	
21	.53	
22	.56	
23	.58	
24	.61	
25	.63	
26	.66	
27	.69	
28	.71	
29	.74	
31	.79	
32	.81	
33	.84	
35	.89	
37	.94	
38	.97	
39	.99	
40	1.02	
41	1.04	
42	1.07	
43	1.09	
47	1.19	
52	1.32	
55	1.40	
60	1.52	
63	1.60	
67	1.70	
70	1.78	
73	1.85	
76	1.93	
79	2.01	
81	2.06	
86	2.18	
89	2.26	
94	2.39	
96	2.44	
100	2.54	
104	2.64	
109	2.77	
113	2.87	
120	3.05	
125	3.18	

Type AM
4-35

Type IA
4-63

Type IAS
4-35

Type IB
4-25

Type IC
4-63

Type ID
4-125

Type IE
4-35

Type IF
4-63

Type IJ
4-125

Type IK
4-20

Type IL
4-35

Type U
4-63

Type US
4-35

Type AM

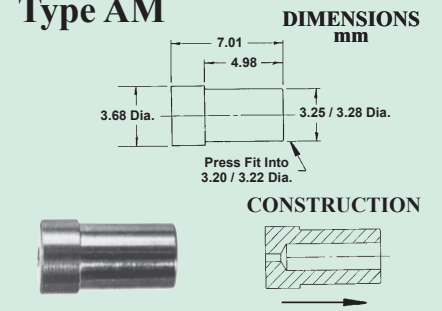

Type IA

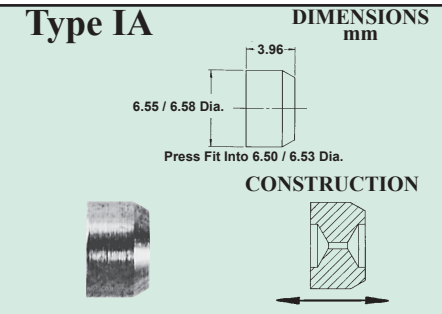

Type IAS

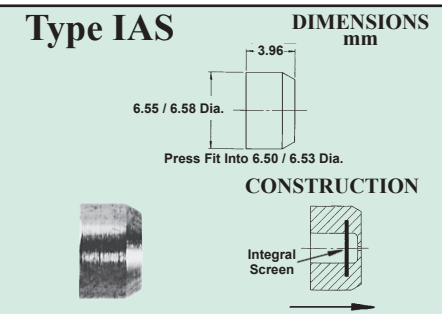

Type IB

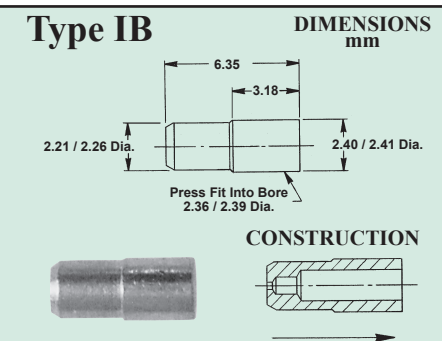

Custom Inserts

Where quantity requirements exceed 1000 pieces, custom inserts can be manufactured in brass, stainless steel, or special materials to the dimensions required. Provide a dimension drawing, material specifications, and quantities to our technical service department to obtain price and delivery quotations.

INSERTS

Type IC
Press Fit Into
4.84 / 4.85 Dia.

DIMENSIONS mm

4.80 / 4.91 Dia.
4.67 / 4.72 Dia.
3.18
4.83

CONSTRUCTION

Type IF
Press Fit Into
6.29 / 6.31

DIMENSIONS mm

6.86
6.32 Dia.
6.34
10-32 Thread

CONSTRUCTION

Type IL
Press Fit Into
2.49 / 2.51

DIMENSIONS mm

2.03
2.53 Dia.
2.54

CONSTRUCTION

Type ID
Press Fit Into
10.48 / 10.50

DIMENSIONS mm

11.2
10.51 Dia.
10.52

CONSTRUCTION

Type IJ
Press Fit Into
9.61 / 9.64

DIMENSIONS mm

6.86
9.65 Dia.
9.66
10-32 Thread

CONSTRUCTION

Type U
Press Fit Into
7.10 / 7.12

DIMENSIONS mm

7.11
7.14 Dia.
7.15
19°

CONSTRUCTION

Type IE
Press Fit Into
3.12 / 3.14

DIMENSIONS mm

1.52
3.15 Dia.
3.18

CONSTRUCTION

Type IK
Press Fit Into
1.54 / 1.55

DIMENSIONS mm

1.57
1.56 Dia.
1.58
.79 Spherical R.

CONSTRUCTION

Type US
Press Fit Into
7.10 / 7.12

DIMENSIONS mm

5.84
7.15 Dia.
7.18
Screen Both Ends

CONSTRUCTION

Part Numbers

The complete part number for an orifice assembly includes Type, Size Number, Body Material and Options.

EXAMPLES

Type	Size Number	Body Material	Options	Part Number
IB	6 (.15 mm)	SS	–	IB-6-SS
AM	10 (.26 mm)	SS	–	AM-10-SS
IA	20 (.51 mm)	Brass	–	IA-20-BR

Orifice Diameters

See chart on page 4 for sizes available for each insert type. Consult factory for other sizes.

Flow Direction

Metal orifice assemblies can be used for flow in either direction. The data on page 7 is for a flow direction as shown in the right column on page 4 and throughout this page.

Check Valves

METRIC ECONOMY LINE

Description

This miniature check valve line employs a free floating stainless steel or elastomeric ball, which allows free flow in one direction; reverse flow is prevented. The valves are suitable for air, water, inert gases, light oil and liquids compatible with the materials of construction. The valves are fast acting and are suitable for long life applications.

Features

- All metal construction option
- Long life operation
- Low cost

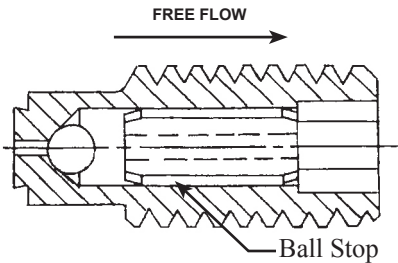

Symbol-Check Valve

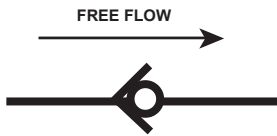

Part Numbers

The complete part number for an orifice assembly includes Type, Fixed Numbers, Thread Size, Body/Ball Stop Material and Ball Material.

(Fixed Numbers are the valve body orifice and differential pressure above which the valve will allow flow in the free flow direction.)

EXAMPLES

Type	Thread Size	Body/ Ball Stop	Ball Material	Part Number				
				Type	Fixed	Size	B/BS	Ball
ZMC (no nose seal)	M3.5	BR (Brass)	SS (440C)	ZMC	- 30 - 0	- M3.5 -	BR -	SS
ZMNBC (nose seal-Nitrile)	M5	SS (303 SS)	B (Nitrile)	ZMNBC	- 47 - 0 -	M5 -	SS -	B
ZMNVV (nose seal - Fluorocarbon)	M6	BR (Brass)	V (Fluorocarbon)	ZMNVV	- 70 - 0 -	M6 -	BR -	V
ZMC (no nose seal)	M8	SS (303SS)	SS (440C)	ZMC	- 94 - 0 -	M8 -	SS -	SS

General Specifications

Materials of Construction

Body – Brass or 303 SS

Ball Stop – Brass or 303 SS

Ball – Nitrile (B), Fluorocarbon (V) or 440C Stainless Steel (SS)

M3.5 - SS M5 - SS or B

M6 - SS or V M8 - SS, B, or V

Maximum Temperature

Nitrile – 70°C

Fluorocarbon - 166°C

Maximum Operating Pressure

Type ZMC

Brass – 3500 kPa (SS Ball)

SS – 7000 kPa (SS Ball)

Type ZMNBC, ZMNVV

1400 kPa

Seat Leakage

SS Ball

20 sccm (max) air flow at 175 kPa

Nitrile or Fluorocarbon Ball

0 sccm @ 350 kPa (air flow)

<5 sccm @ 175 kPa (air flow)

Flow Capacity (air flow)

Type	Size	K_v	(SLPM) @ 350 kPa*
ZMC	M3.5	.009	12
ZMC	M5	.034	48
ZMC	M6	.064	80
ZMC	M8	.100	130

* data from flow chart

Thread Sealant

For type ZMC straight threads use

Loctite 542 thread sealant or equal.

Construction

Types ZMNBC, ZMNVV



Type ZMC

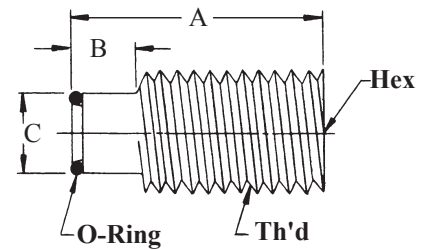
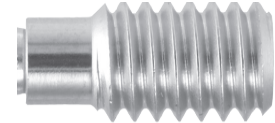

Dimensions - mm

Th'd	A	B	C	Hex
M3.5	7.87	1.97	2.29	2
M5.0	10.8	2.57	3.10	2.5
M6.0	12.7	3.81	4.45	3
M8.0	16.3	4.83	5.59	4

Installation

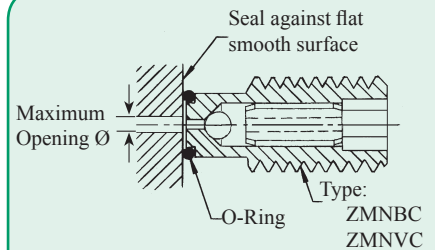

Dimensions - mm

Thread	Maximum Opening Ø
M3.5 x 0.6 mm	1.20
M5.0 x 0.8 mm	1.57
M6.0 x 1 mm	2.41
M8.0 x 1.25 mm	3.18

